



Curio Table

Plan No. 854

Copyright U-Build, Inc., 2003.
All rights reserved. Printed in the U.S.A.

If you like to collect things, this handsome curio coffee table can help ease the storage crunch. The project is topped with a piece of heavy glass with a drawer underneath that provides almost four square feet of display space.

The curio table measures about 38 inches long by 24 inches deep by 17 inches tall.

Bill of Material

Qty	Size	Material	Item
1	3/4" x 48" x 96"	oak plywood	D, G, H, P, Q
1	1/2" x 48" x 48"	oak plywood	R
1	1 1/2" x 1 1/2" x 150"	oak	A, B, E
1	1 1/2" x 2" x 110"	oak	C, F, J
9 bd. ft.	3/4"	oak	I, K, L, M, N, O, S
48	3/8" x 1"	oak dowels	
4	1 1/2"	wood knobs	
1	1/4" x 17 5/8" x 31 5/8"	tempered glass	
16	3/8"	flat plugs	
16	1"	coarse drywall screws	
1 box	1"	finish nails	
1 box	1 1/4"	finish nails	
1 bottle		wood glue	
1 can		oak wood filler	
1 quart		stain	
1 quart		finish of choice	

Cutting Schedule

Item	Qty	T	W	L	Material
A	4	1 1/2"	1 1/2"	16 1/4"	oak
B	2	1 1/2"	1 1/2"	19"	oak
C	2	1 1/2"	2"	19"	oak
D	2	3/4"	11 1/2"	19 3/4"	oak plywood
E	1	1 1/2"	1 1/2"	33"	oak
F	1	1 1/2"	2"	33"	oak
G	1	3/4"	11 1/2"	33"	oak plywood
H	1	3/4"	19"	33"	oak plywood
I	2	3/4"	1 1/2"	33"	oak
J	1	1 1/2"	2"	33"	oak
K	4	5/16"	3/4"	19 1/2"	oak
L	1	3/4"	7/8"	33"	oak
M	2	3/4"	7/8"	18 1/8"	oak
N	2	3/4"	3 1/4"	37 1/2"	oak
O	2	3/4"	3 1/4"	17"	oak
P	4	3/4"	5 1/8"	19 3/4"	oak plywood
Q	4	3/4"	4 1/8"	31 3/8"	oak plywood
R	2	1/2"	32"	19 3/4"	oak plywood
S	2	3/4"	5 3/16"	32 7/8"	oak

NOTES

- Read manufacturer's instructions before operating equipment.
- **Always** wear safety glasses.

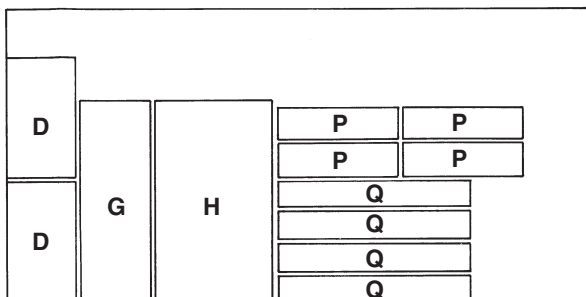

3/4" x 48" x 96" Oak Plywood
Cutting Layout

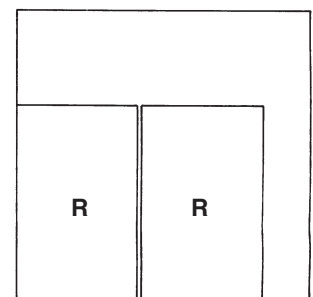

1/2" x 48" x 48" Oak Plywood
Cutting Layout

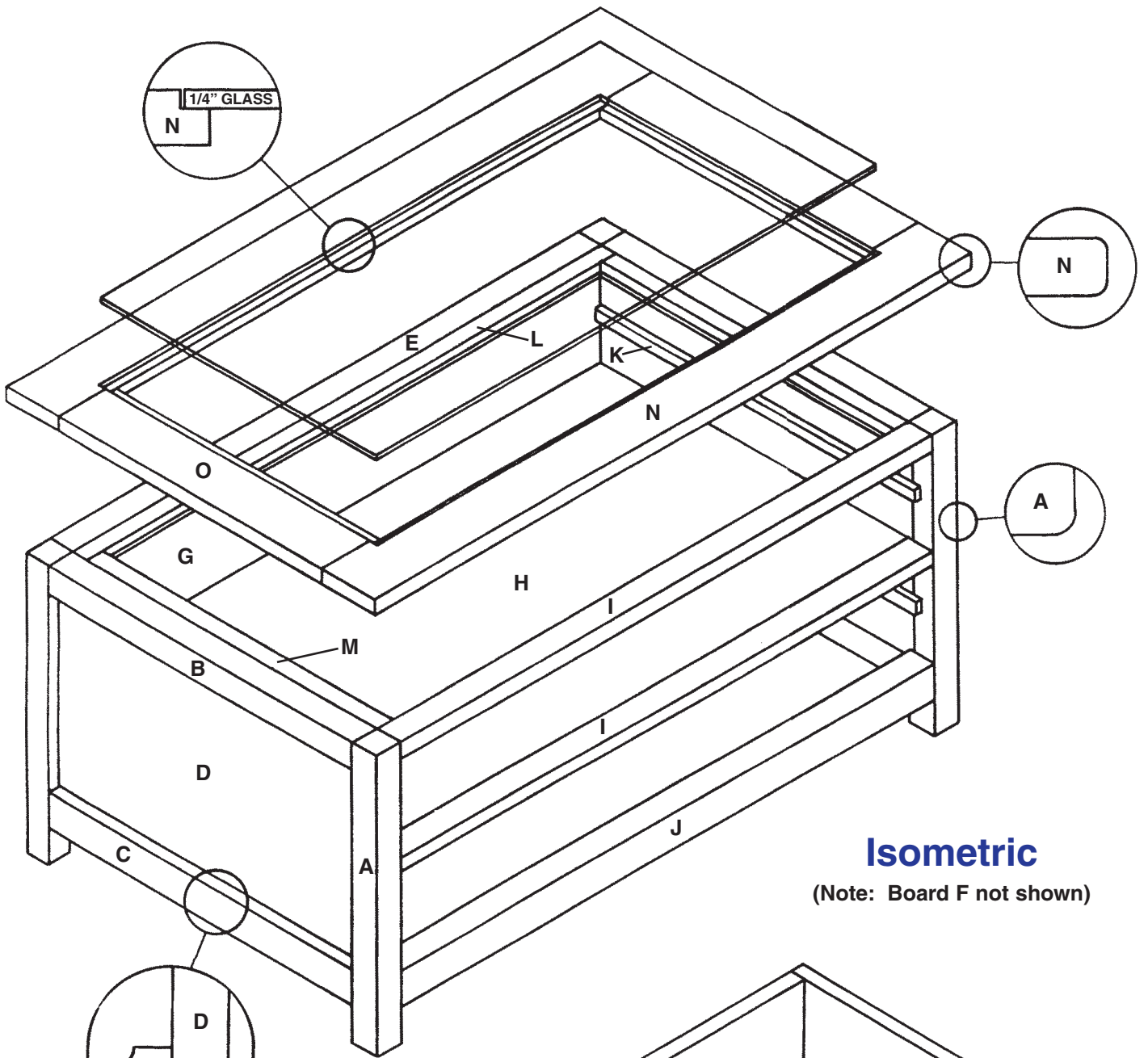

Isometric
(Note: Board F not shown)

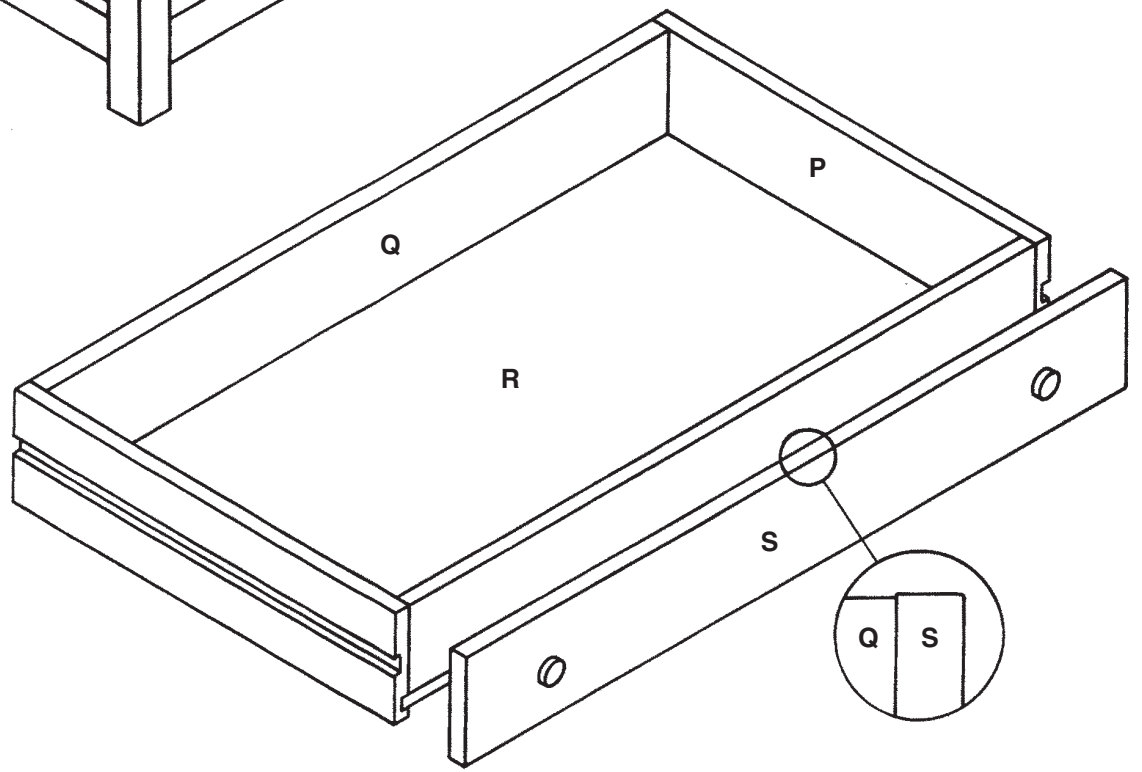
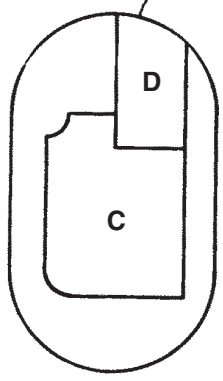

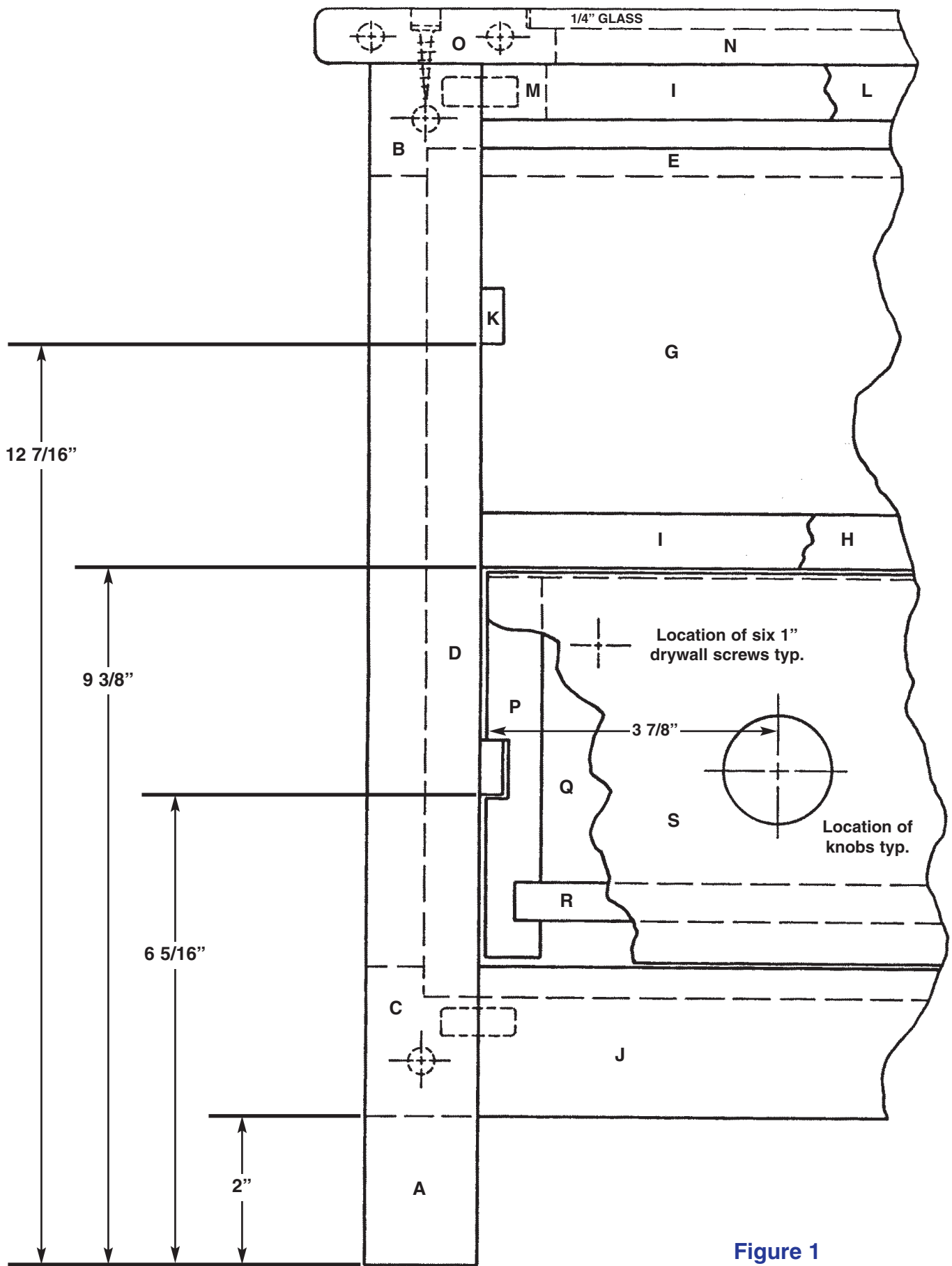

Figure 1
Curio Coffee Table Cross Section

Assembly Instructions

Page One

Read all instructions before beginning any work. Cut all material to sizes shown in cutting schedule.

1. Attach boards (A) to boards (B) and (C) using glue and dowels. Refer to Isometric and Figure 1.
2. Rout a $3/8"$ by $3/4"$ deep rabbet around inside edges of side subassemblies (A, B, C). Radius the corners of boards (D) and glue in place. Refer to Isometric and Figure 1.

3. Rout a $3/8"$ by $3/4"$ deep rabbet on one edge of boards (E) and (F). Glue (E) and (F) to board (G). Refer to Figure 2.

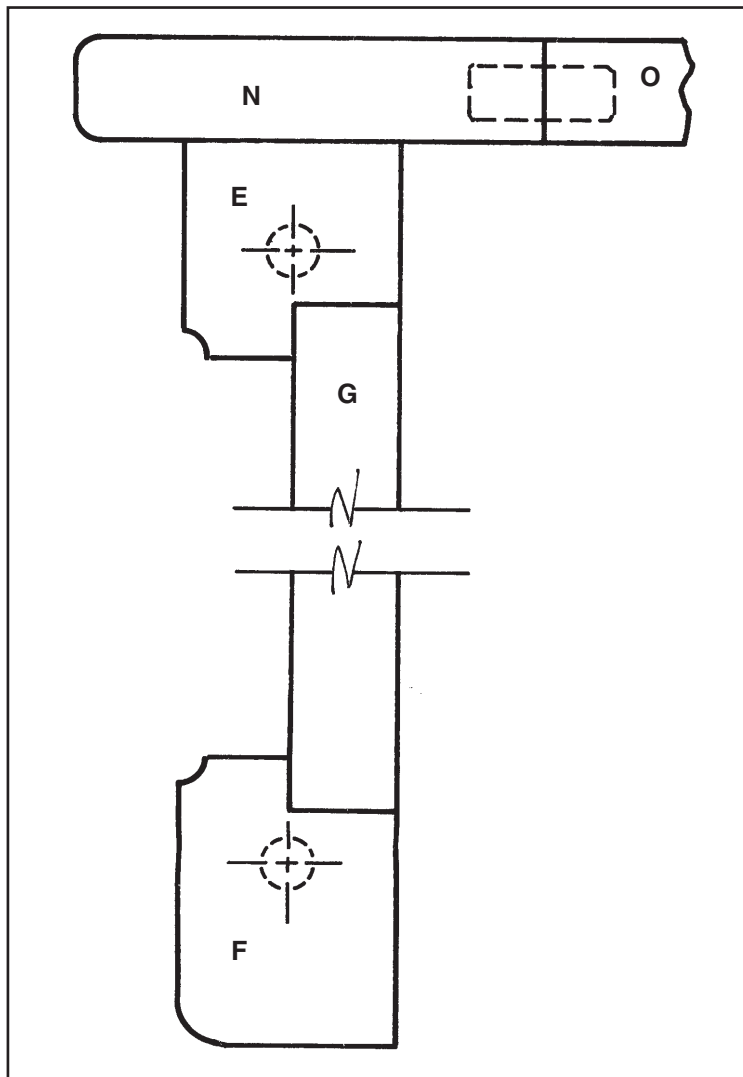

Figure 2
Boards (E), (F), (G), (N), (O)

4. Attach subassembly (E, F, G) and upper board (I) and board (J) to sides (A, B, C, D) using glue and dowels. Refer to Isometric and Figures 1 and 2. Note: Do not install lower board (I) at this time (see Step 5).

Assembly Instructions

Page Two

Read all instructions before beginning any work. Cut all material to sizes shown in cutting schedule.

5. Glue board (I) to board (H). Use 1 1/4" finish nails and glue to attach subassembly (H, I) to boards (D) and (G). Refer to Figure 1 for location.
6. Rout an optional decorative 1/4" cove around inside edges of boards (A), (B), (C), (E) and (F). Stop the cove 1" from the ends of each board. Refer to Isometric and Figure 2.
7. Rout a 1/4" radius on outside corners of boards (A). Refer to Isometric.
8. Attach drawer rails (K) to boards (D) using 1" finish nails and glue. Refer to Isometric and Figure 1.
9. Glue board (L) to board (E) and boards (M) to boards (B). Refer to Isometric and Figure 1.
10. Attach boards (N) to boards (O) using glue and dowels. Refer to Isometric and Figure 1.
11. Rout a 1/4" radius around the outside edges of boards (N) and (O). Refer to Isometric and Figure 1.
12. Attach top frame (N, O) to the table base using glue and 1" drywall screws. Countersink and cover the screws with 3/8" plugs. Refer to Isometric and Figure 1.
13. Rout a 1/4" deep by 3/8" wide rabbet on the inside edges of top frame (N, O) to accommodate the glass. Refer to Isometric and Figure 1.
14. Rout a 3/8" deep by 13/16" wide dado down the center of one side of boards (P). Rout a 3/8" deep by 1/2" wide dado on the opposite side of boards (P) to accommodate drawer bottoms (R). Refer to Isometric and Figure 1.
15. Assemble boards (P) to boards (Q) using glue and 1 1/4" finish nails. Slide drawer bottoms (R) into the grooves on boards (P). Attach (R) to (Q) using 1 1/4" finish nails. Refer to Isometric and Figure 1.
16. Attach drawer fronts (S) to boards (Q) using six 1" drywall screws. Space the screws 1 1/2" from the ends of the drawers and 1" from the top and bottom edges. Countersink and cover the screws with 3/8" plugs. Refer to Isometric and Figure 1.
17. Attach knobs to drawer fronts (S). Refer to Figure 1.
18. Stain and finish project.
19. Cut glass to fit and place in rabbet on top frame (N, O).